

SISGEO®
RAIL
IOT IN MOTION

WIRELESS LoRaWAN®

FLX-RAIL®

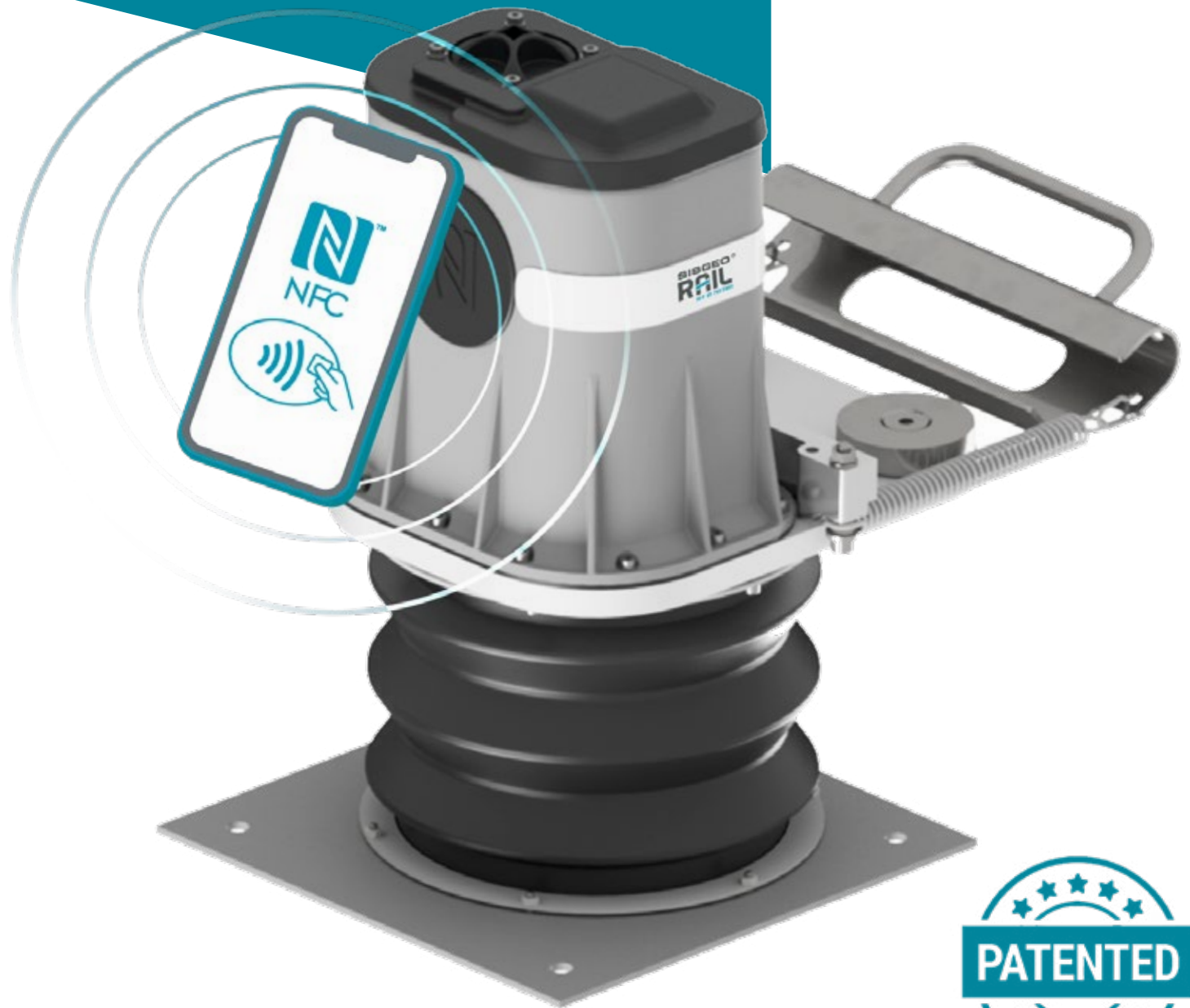

WIRELESS LoRaWAN[®]

FLX-RAIL[®]

The FLX-Rail[®] automatically and continuously measures the maximum vertical deformation of the rail at each passage of a train, a phenomenon commonly known as "rail swing" or "rail dance". The instrument is installed between the track and the ballast, fixed under the rail using two powerful magnets: this solution allows quick and easy installation. The measurements are then immediately transmitted via LoRaWAN using 868MHz frequency: ensure whether there is radio coverage at the installation site through a local service provider (SISGEO does not provide LoRaWAN gateway).

The FLX-Rail[®] is equipped with an innovative technology called SBV[®] (Start By Vibe), patented, which activates the instrument just before the train passes. The FLX-Rail[®] can also be equipped with a biaxial inclinometer (MEMS technology) for static rail tilting monitoring.

The instrument is powered with D-type batteries and is available in two versions: both non-rechargeable and rechargeable batteries can be used.

The FLX-Rail[®] (rechargeable models available only under request) is managed by a user-friendly free APP for Android and iOS by NFC (Near Field Communication).

FEATURES

- Certified according to the severe environmental standards EN 50125-3 (rail level).
- SBV[®] technology to wake up the instrument for saving power consumption.
- Each FLX-Rail[®] gauge is individually calibrated.
- Compact dimensions.
- Easy to install and to remove without any tool
- FLX-Rail[®] gives a number of diagnostic information such as voltage supply, internal temperature and humidity, and GPS position at configuration stage.



STANDARD COMPLIANT:

DIRECTIVE 2014/53/EU

EN 50121-4:2016+A1:2019 (EMC for Railways)

EN 60529 (IP-class degree)

EN 62262 (IK-class degree)

EN 50125-3 clause 4.13 (Vibrations)

Invention patent nr.102020000031274



SBV[®]
TECHNOLOGY

WORKING PRINCIPLE

The FLX-Rail® is fixed with two magnets and a fixing handle(1) to firmly place the gauge under the rail foot. The installation is performed without any tool. A reference plate is leaned beneath the ballast, so that the instrument is able to read the relative movement between the rail and the ballast, while traffic is present. The reading frequency of the rail vertical movement is 350Hz and is activated only during the train's passage, thanks to SBV® technology. Every FLX-Rail®, send via LoRaWAN the maximum value registered at each train's passage. The biaxial rail inclination (option) and diagnostic sensors (internal temperature, humidity and supply voltage) are detected only under static conditions (without train passage). Reading frequencies and GPS position can be set by the user via the mobile app.

(1) The fixing handle is designed for the rail profile 50e6. Please contact your Sisgeo sales representative to verify the compatibility with other rail section

MONITORING UNDER LOAD - TRAIN PASSAGE

Reading of rail vertical movement

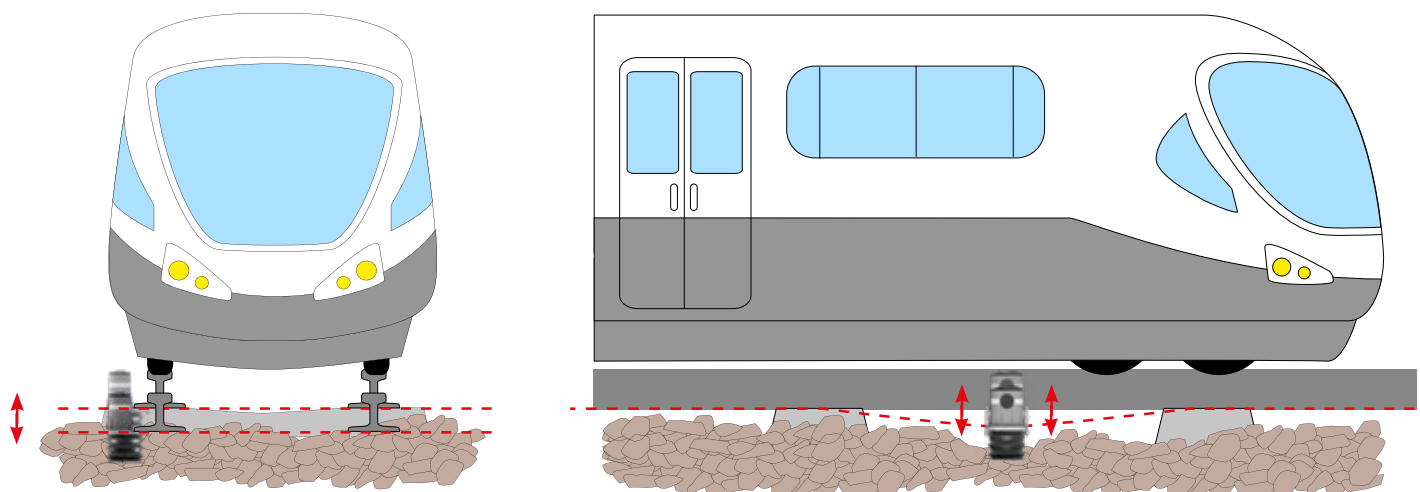

STATIC MONITORING - NO TRAIN

Reading of rail biaxial tilting (option)

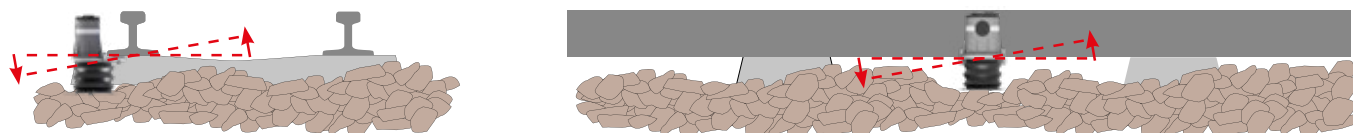

PHYSICAL FEATURES

FLX-RAIL

Overall dimensions	200 x 232 x 300 mm
Working temperature range	-30°C to +70°C (battery temperature range may be different and more restrictive)
IP class	IP 67
IK class	IK 08
Material	Aluminum, stainless steel, galvanized steel, special compound of polycarbonate
Weight (without batteries)	About 4 kg

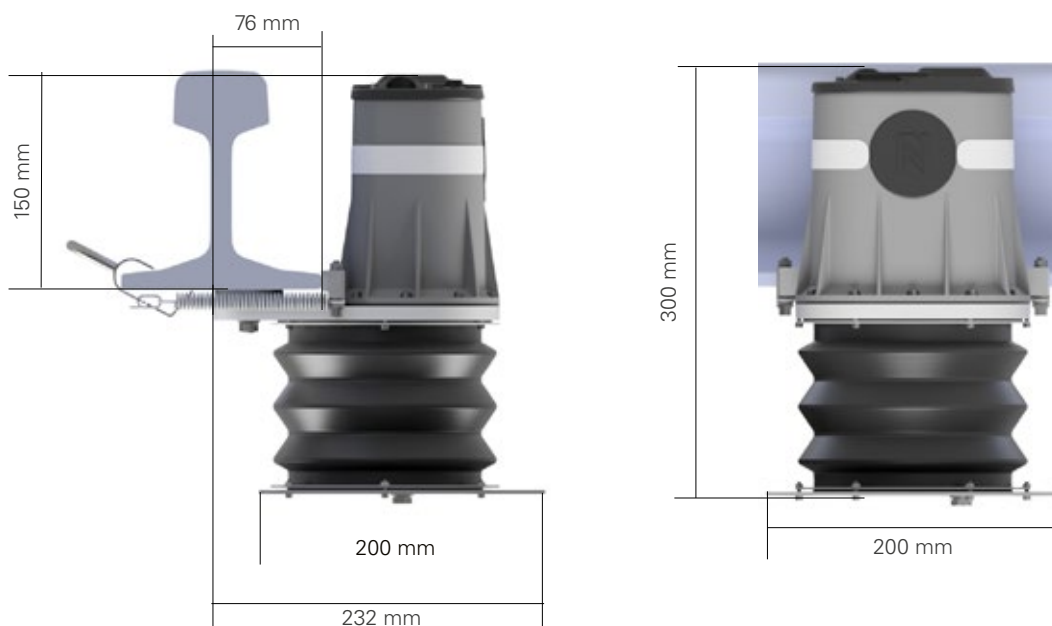

TECHNICAL SPECIFICATIONS

DYNAMIC DEFLECTION SENSOR

Sensor type	Optic
Full scale	70 mm
Sensor resolution	0.01 mm
Reading frequency	350 Hz
Offset temperature dependency	0.03 mm/°C
Sensor repeatability	±0.01 mm
Sensor 24 hours stability ⁽¹⁾	±0.1 mm
Sensitivity ⁽²⁾	See Calibration Report
Sensor accuracy (MPE) ⁽³⁾	<±0.1 mm

TECHNICAL SPECIFICATIONS

EMBEDDED TILT SENSOR (OPTION)

Sensor type	MEMS accelerometer
Measuring range	±15°
Sensor resolution	0.0001°
Sensor repeatability ⁽¹⁾	<±0.001°
Sensitivity ⁽²⁾	See Calibration Report
Sensor accuracy (MPE) ⁽³⁾	<±0.02 % FSR
Sensor 24 hours stability ⁽⁴⁾	<±0.004° (±0.07 mm/m)
Sensor mechanical bandwidth	1 Hz
Offset temperature dependency	±0.002° / °C

INTERNAL TEMPERATURE SENSOR ⁽⁵⁾

Measuring range	- 40°C to +125°C
Accuracy	±1°C with temperature range -10°C to +85°C

INTERNAL HUMIDITY SENSOR ⁽⁵⁾

Measuring range	0 to 100% RH
Accuracy	±5% RH with humidity range 0 to 95% RH

SUPPLY VOLTAGE MONITOR ⁽⁵⁾

Measuring range	0 to 18 V for both batteries
Accuracy	±5% FS

ELECTRICAL INFORMATION

Power supply ⁽⁶⁾	2 V to 6 V (rechargeable batteries) 6 V to 28 V (non-rechargeable batteries)
-----------------------------	---

LORAWAN INFORMATION

Frequency and power	868 MHz Band (863-870 MHz), 25 mW (14dBm) max
LoRaWAN version	LoRaWAN Specification 1.0.4
Activation mode	RP002 Regional Parameters 1.0.3
Regional Parameters version	OTAA

AUTONOMY ⁽⁷⁾

Rechargeable version (2.4Vdc Supply = 2x1.2 V, NiMH, 9 Ah, size D)	3 months Signal condition: SF=7; SNR=9.8; RSSI=-84; temperature=20°C Considering 100 train transits (event) per day, event duration 15* and 6 periodical acquisition per day for diagnostics sensors and tiltmeter
Not rechargeable version (7.2Vdc Supply = 2x3.6V, 19.0Ah, LiSOC12, size D)	32 months Signal condition: SF=7; SNR=13; RSSI=-81; temperature=20°C considering 100 train transits (event) per day, event duration 15* and 6 periodical acquisition per day for diagnostics sensors and tiltmeter

(1) Repeatability error calculated as maximum error of ten repetition of measuring points at 10% and 90% FSR.

(2) Sensitivity is a specific parameter different for every gauge. The sensitivity is calculated during gauge calibration test and inserted into the Calibration Report.

(3) MPE is the Maximum Permitted Error on the measuring range (FSR). In the Calibration Report, the accuracy of the gauge is calculated using the linear regression.

(4) Stability calculated as difference after a 24 h period under repeatability conditions.

(5) These sensors are installed on the internal electronic board for sensor diagnostics.

(6) Only batteries validated by SISGEO will be allowed to be used. Verify the working temperature range according to the batteries' model

(7) Data obtained from simulations

AVAILABLE VERSIONS AND ACCESSORIES

- RFLXWR70000** WIRELESS FLX-RAIL® GAUGE, MODEL WITH RECHARGEABLE BATTERIES, VERT DISPLACEMENT ONLY
vertical displacement range 70mm, including fixing kit with handle and springs.
- RFLXWD70000** WIRELESS FLX-RAIL® GAUGE, MODEL WITH DISPOSABLE BATTERIES, VERT. DISPLACEMENT ONLY
vertical displacement range 70mm, including fixing kit with handle and springs.
- RFLXWR70300** WIRELESS FLX-RAIL® GAUGE, MODEL WITH RECHARGEABLE BATTERIES, VERT DISPLACEMENT AND RAIL TILT
vertical displacement range 70mm, biax tilt sensor range $\pm 15^\circ$, including fixing kit with handle and springs.
- RFLXWD70300** WIRELESS FLX-RAIL® GAUGE, MODEL WITH DISPOSABLE BATTERIES, VERT. DISPLACEMENT AND RAIL TILT
vertical displacement range 70mm, biax tilt sensor range $\pm 15^\circ$, including fixing kit with handle and springs.
- RFLXWRBATTO** PAIR OF RECHARGEABLE BATTERIES
2x 1.2V V, 9 Ah, D-size, NiMH, rechargeable batteries. Working temperature range: from -20° to $+50^\circ\text{C}$
- RFLXWDBATTO** PAIR OF DISPOSABLE BATTERIES
2 x 3.6 V, 19 Ah, D-size, LiSOCl2, disposable batteries. Working temperature range: from -55° to $+85^\circ\text{C}$
- RFLXWCHARG** BATTERY CHARGER (FOR RECHARGEABLE BATTERIES ONLY)
4-slot charger with protections for lithium-ion and NiMH charging.
- RFLXWBATREM** TOOL FOR BATTERIES REMOVAL

FLX-RAIL APP FOR GAUGE SET-UP



Welcome page



Main menu

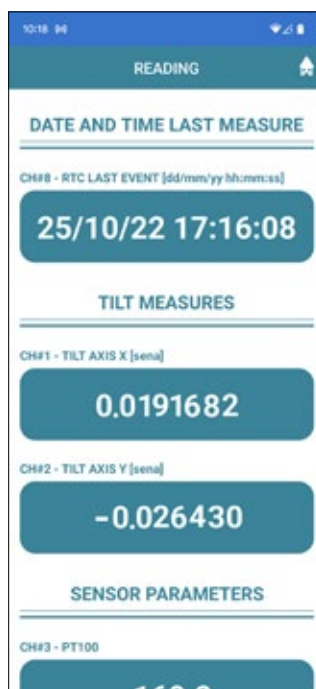

Reading page with tilting values



Reading page with diagnostics sensors readings

Minimum Device Specifications
(device not supplied by SISGEO)

ANDROID OS V. 11 or higher with NFC capabilities
APPLE iOS V. 17 or higher with NFC capabilities



AIDA - ARTIFICIAL INTELLIGENCE DATA ANALYSIS



FIELD S.r.l., as part of Sisgeo Group, has developed AIDA IoT, a dedicated service for data/measurement management for automatic and manual monitoring systems.

Measurements provided by the FLX-Rail® are sent through LoRaWAN and then forwarded to a dedicated server. AIDA IoT organizes data and provide both graphical and tabular views.

The AIDA IoT platform provide nearly real-time charts, showing both maximum displacement, inclinations and temperature. Also complex calculations can be displayed on specific chart.

For further information, visit the dedicated web page on the Field Srl web site: <http://www.aidaiot.com/>

This AIDA IoT screenshot shows the histogram with the maximum displacement for each train passage. Enlarging the zoom makes possible to verify at which time the train has passed on the FLX-Rail® installation point, as well as the corresponding maximum vertical displacement reading.



This plot shows short twist from pairs of FLX-Rail® installed 3m apart.

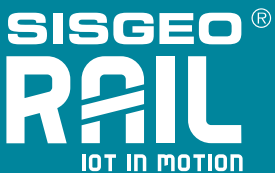

A SISGEO BRAND

Via F. Serpero 4/F1
20060 Masate (MI) Italy
Phone +39 02 95764130
Fax +39 02 95762011

info@sisgeo.com

WWW.SISRAIL.COM

AFTER SALES SUPPORT

SISGEO offers customers e-mail and phone assistance to ensure proper use of instruments and readout and to maximize performance of the system. For more information, email us: assistance@sisgeo.com

All the information in this document is the property of Sisgeo S.r.l. and should not be used without permission from Sisgeo S.r.l. We reserve the right to change our products without prior notice. The datasheet is issued in English and other languages. In order to avoid discrepancies and disagreement on the interpretation of the meanings, Sisgeo Srl declares that English Language prevails.